

WATER VALVE REBUILD

MODELS: 80VP, 125VP



WARNING

LP & NG ARE EXTREMELY FLAMMABLE SO TAKE EXTRA PRECAUTIONS WHEN PERFORMING ANY WORK TO THE HEATER

WATER VALVE MAINTENANCE AND SERVICE - AquaStar Models 80/125 VP

The AquaStar Water Valve Assembly requires periodic maintenance. Some of the components need to be replaced every two (2) to five (5) years. Exactly how often depends on water conditions and use. Failure to maintain this assembly could result in unsafe operation of the gas valve and costly damage to the rest of the heater.

Indications That Your Water Valve Assembly (# 34343) Could Need Service:

- Any signs of a white or greenish powdery substance where the brass Water Valve Assembly (#34343) joins the aluminum Gas Valve Housing (# 21108).
- Dripping water from the weep hole located at the same joint. See location of weep hole on page 2. An indication that water may be coming from the weep hole can be seen on the silver tray at the bottom of the heater.
- Any instances of freezing damages.
- If due to high mineralization in the water valve (usually on older heaters) the burners will fail to go off immediately when the water is turned off. To test for this possibility run hot water at a faucet, then while the Aquastar is on shut off the cold inlet supply and observe if the burners go off immediately. If they do not the Aquastar will overheat and shutdown on safety depending on the delay.
- High flow rate is required to activate heater. 3/4 of gallon per minute should be the minimum required.
[In each of these cases the water valve inner assembly will need to be replaced and the water valve body may require descaling.]
- *If the burners fail to activate at the minimum flow of 3/4 gallons per minute.* In a recent installation this problem could simply be some debris in the water valves venturi piston chamber. To fix this begin by first shutting off the water inlet supply, then remove the piston assembly (#34542) from the water valve, now with a container in place reopen the water inlet and flush water through it. In an older heater the problem could be due to heavy mineralization in the water valve and will require the water valves components to be replaced and the water valve body descaled. **Note:** a plumbing crossover somewhere in the house can also be responsible for this. To establish if there is a plumbing crossover simply shut off the water supply to the heater and turn on all the hot water faucets being served by the Aquastar, if there is flow then you have a crossover in your plumbing and it will need to be fixed.

A complete kit to rebuild the Water Valve a) Pushrod # 21107 and 2 washers for water connections.

Assembly consists of these parts:

- b) Diaphragm # 32570
- c) Piston # 34542
- d) Lubricant pack #DOWLUBE

If in need of parts or service, visit us on the web at www.boschheating.com.

A. Preparation

Tools Needed:

- Screwdriver
 - Adjustable wrench
 - Container to catch water
1. Shut off gas and water supply to heater and open a faucet to relieve pressure in water line
 2. Pull off knobs on the front cover.
 3. Remove the two (2) screws at the bottom front corners of the front panel.
 4. Pull bottom of panel towards you, then lift up and out.
 5. Remove bottom tray if necessary.

B. Removing the Water Valve Assembly - see fig.1

1. Loosen the two (2) tube connection fittings on the Water Valve Assembly (have a container ready for the water that will drain). Also loosen the

connecting tube at the mounting bracket (Fig. 2 on page 2). Do not lose the washers for these joints.

2. Loosen Set Screws (# 22064) which retain the water valve to the gas valve - do not remove them. If Set screws (#22064) do not unscrew easily...do not force them... you could damage the gas valve.
 - Call 800-642-3111 for help
3. Once the 2 screws are loose rotate the Water Valve Assembly away from water connections and pull Water Valve Assembly out of the Gas Valve Housing.
4. NOTE: As the Brass Water Valve starts to separate from the aluminum housing, hand tighten one of the set screws (# 22064) to retain the Gas Valves inner parts.

C. Cleaning the Water Valve Assembly Parts

1. Remove the Water Valve Piston and spring assembly (# 34542) See Fig. 1 on page 2.
2. Remove the Pushrod (# 21107). On the plastic end of the pushrod there should be a small o-ring. If it is not there then it's seated in the water valve. Simple pick it out and keep it with the pushrod.
3. Remove the five retaining screws to separate the two halves of the Water Valve Housing (# 20596 and # 20597) and remove the diaphragm (#32570). If it is stiff then replace it.
4. Be careful not to lose the Centering Tube (# 20799) and note its location. Blow through it to assure it's clean.
5. Soak the two halves of the water valve housing in white vinegar or other descaling solution to remove any mineral deposits.

WATER VALVE REBUILD

MODELS: 80VP, 125VP

FIG 1

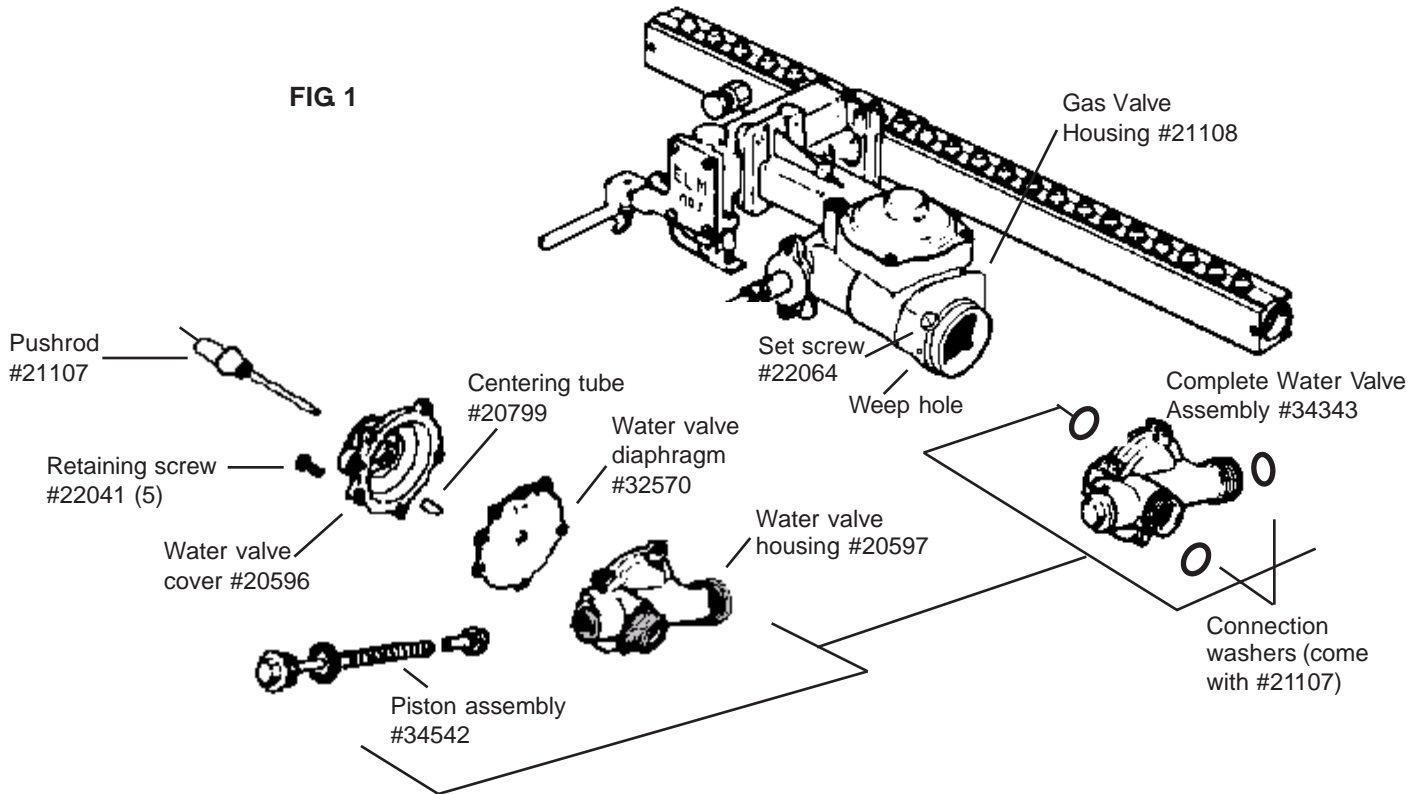

D. Re-assembling the Water Valve Assembly

1. Place the Centering Tube (# 20799) in the non-threaded hole at the edge of the water valve housing.
2. Position Diaphragm (# 32570) on the Water Valve Housing (# 20597).
 - Side with brass metal plate should face toward the gas valve housing (#21108).
3. Screw both halves of the water valve (#20596 and #20597) together.
4. Re-assemble the water valve piston (#34542) - place the plastic piston in the barrel of the water valve assembly with the hollow stem facing up. Next, place the spring over the plastic piston and then insert the brass plug so that its pin goes through the spring and into the hollow stem of the plastic piston.
5. Liberally apply supplied lubricant to pushrod. Replace the pushrod (#21107) - be sure a small o-ring is around its plastic collar before inserting it into the water valve. The side of the collar which is brass will have an o ring as well.

E. Insert Water Valve Assembly back into the Gas Valve Housing

1. While pressing the water valve to the gas valve opening loosen the 2 Set Screws (# 22064) so that the Water Valve Assembly can be inserted all the way in.
2. Rotate Water Valve Assembly into proper position - then tighten set screws (# 22064).
3. Connect the inlet connecting tube to the water valve (see Fig.2) - make certain the washer that came with (#21107) is in place - **do not over tighten.**
4. Connect the Heat Exchanger tube to the water valve (see Fig.2) - make certain the washer that came with (#21107) is in place - **do not over tighten.**
5. Retighten connecting tube at the mounting bracket.

F. Completion

1. Open water inlet and check for leaks.
2. Open gas inlet; check for leaks then light pilot.
3. Run hot water and check for minimum flow activation of burners.

FIG 2

